

VISION FOR A RISK ADVERSE **INTEGRATED GEOMETALLURGY** FRAMEWORK

GUILLERMO TURNER-SAAD, GLOBAL VICE PRESIDENT METALLURGY AND MINERALOGY, SGS MINERAL SERVICES

ABSTRACT

Best practice in the economic evaluation of mining projects and operations is based on the integration of geological, mining, metallurgical, environmental, marketing, economic and corporate information and strategies. Fundamentally, the economic evaluation takes into account mining, blending, stockpiling, processing, smelting, refining and marketing ore resources with grades estimated by geostatistical methodologies.

Nevertheless, a realistic economic evaluation consists of a concurrent and integrated optimization process that maximizes the concentrates or products of liberated and selected ore minerals from mineral deposits. The optimum solution is obtained through a trade-off among mining, blending, stockpiling and processing ore reserves with distinct mineralogy and texture characteristics. The concurrent optimization determines both the practical mining sequence of ore reserves and the dynamic and robust mineral processing flowsheet design over the expected life of mining projects and operations.

A combined risk-adverse and concurrent optimization process takes into account the spatial uncertainty of the mineralogy and texture characteristics of ore reserves. Additionally, a variety of mineral processing linear, non-linear, additive and non-additive parameters modeled spatially. The spatial uncertainty of these ore reserves characteristics and parameters has a direct impact in the expected mining sequence, mineral processing flowsheet design, concentrates or products quantity and quality, and economic value of mining projects and operations.

Geometallurgical domain constrained stochastic geostatistical methodologies and multivariate mathematical models are applied for spatial uncertainty modeling of ore reserves characteristics and parameters. These mathematical models correlate the mineral processing liberation and selectivity responses of the mineralogy and textures within each geometallurgical domain. These models, in turn, are defined based

on results of mineral processing and environmental testwork of unbiased and representative samples chosen for their variability. These samples are selected within mutually exclusive spatial geometallurgical uncertainty domains with similar mineralogical and textural characteristics in mineral deposits.

Geometallurgical domains are defined by applying and combining multivariate statistical analysis and implicit modeling methodologies. These involve determining and constraining mineral processing liberation and selectivity properties explicitly contained in the extensive and integrated exploration drillhole database.

INTRODUCTION

The best practice in economic evaluation of mining projects and operations by applying either net present value or real options analysis is mainly based on the integration of geological, mining, metallurgical, environmental, marketing, economic and corporate information and strategies. In addition, a number of constant and variable information and assumptions are also considered in the evaluation.

Nevertheless, the fundamental information in the assessment is held

in grades and multivariate attributes of mineral resources and ore reserves. In fact, the expected economic value in a particular time period comes from mining, blending, stockpiling, processing, smelting, refining and marketing ore resources with grades and multivariate attributes estimated by geostatistical methodologies.

The basic principle in the economic evaluation considers that mining and processing two discrete ore reserve blocks with the same volume, bulk density, grade and metallurgical recovery would produce a concentrate or product with the same recovered metal content. However, in reality the recovered metal content of these two discrete ore reserve blocks are different and it is essentially due to their individual and intrinsic mineralogy and texture characteristics. It is convenient to note that a concentrate or product is an agglomeration of liberated and selected ore and gangue minerals.

There is a lack of understanding and experience of the mining industry regarding the economic impact of the mineralogy and texture characteristics. These characteristics are the main drivers of mineral processing liberation and selectivity processes of mineral deposits. Additionally, there is an

entire unknown about the expected concentrates or products of liberated and selected ore and gangue minerals by mining, blending, stockpiling and processing ore reserves with similar grades but with different mineralogy and texture characteristics.

It is comprehensible so far that practical and simplistic assumptions and methodologies are not enough in optimizing mining projects and operations economics. This statement has been extensively demonstrated and documented by the historical economic performance of precedent and active mining operations. This means that further source of information and innovative methodologies need to be considered and developed in the mining industry in order to optimize the economics of mining projects and operations.

A pragmatic economic evaluation is based on a simultaneous and integrated optimization process that maximizes the concentrates or products of liberated and selected ore minerals from mineral deposits. The optimum and integrated solution is achieved by a trade-off among mining, blending, stockpiling and processing ore reserves. These ore reserves consist of distinct mineralogy and texture characteristics and mineral processing liberation and selectivity parameters. The concurrent optimization determines both the practical mining sequence of ore reserves and the dynamic and robust mineral processing flowsheet design over the expected life of mining projects and operations.

An advanced risk analysis in the economic evaluation consists in combining risk-adverse and concurrent optimization process. This optimization process takes into account the spatial uncertainty of the mineralogy and texture characteristics in mineral deposits. Additionally, a variety of mineral processing linear, non-linear, additive and non-additive parameters modeled spatially. The spatial uncertainty of these characteristics and parameters has a direct impact in the expected mine design, ore reserves, mining sequence, production scheduling, mineral processing flowsheet design,

concentrates or products of liberated and selected ore minerals, and economic value of mining projects and operations.

This document describes the vision of a risk adverse integrated geometallurgy framework, which is structured in an ordered and coherent sequence of iterative stages. The iterative application of these stages aims to determine the optimum and integrated geological, mining, metallurgical, environmental, marketing, economics and corporate strategies. These strategies allow maximizing the economic value of mining projects and operations based on spatial uncertainty of the variability of mineralogy and texture characteristics in mineral deposits.

GEOMETALLURGY FRAMEWORK

The geometallurgy framework is a risk adverse integrated methodology that supports the corporate strategic planning process of mining projects and operations. This process includes an economic evaluation based on a risk analysis of the spatial uncertainty of the variability of mineralogy and texture characteristics in mineral deposits. The objective function of the economic evaluation consists in maximizing the economic value while minimizing multiple sources of uncertainty. These sources of uncertainty are related to the spatial variability of mineralogy and texture characteristics and mineral processing liberation and selectivity properties in mineral deposits. The optimization is developed by an iterative and integrated process constrained by geological, mining, metallurgical, environmental, marketing, economics and corporate information and strategic planning scenarios.

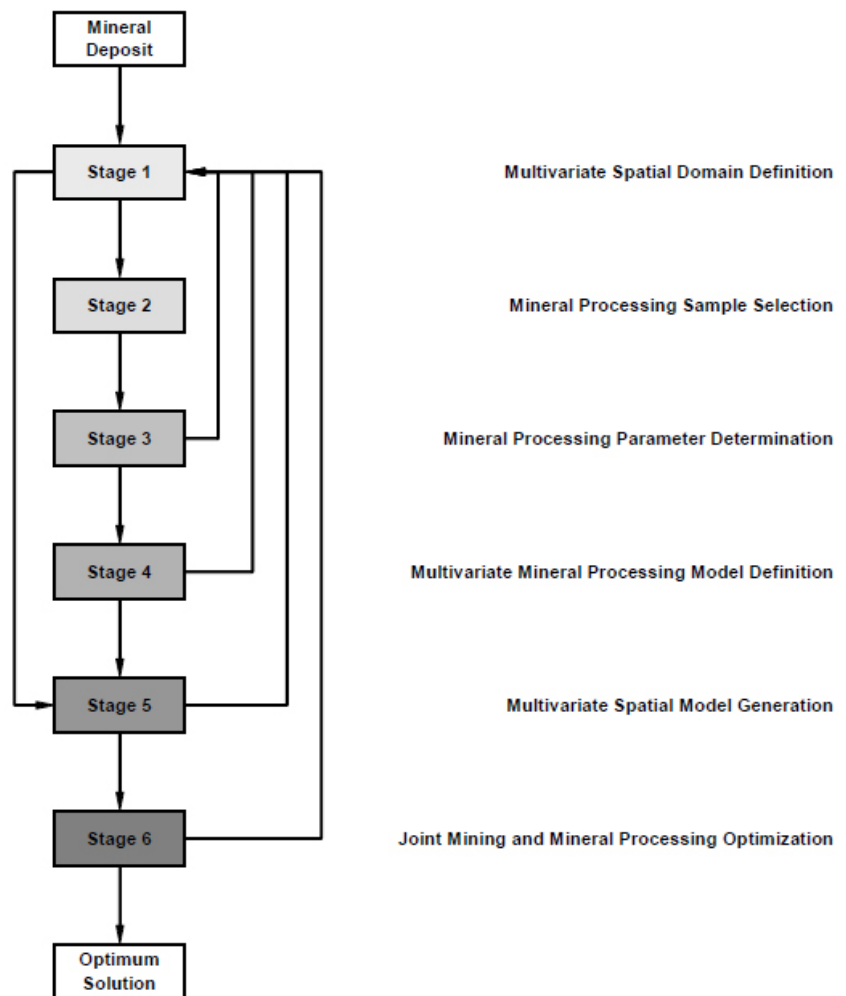

Figure 1: Iterative optimization process of the risk adverse integrated geometallurgy framework

The integrated optimization process is performed by the development and implementation of a structured in an ordered and logical sequence of six iterative stages (Figure 1):

- Stage 1 - Multivariate Spatial Domain Definition
- Stage 2 - Mineral Processing Sample Selection
- Stage 3 - Mineral Processing Parameter Determination
- Stage 4 - Multivariate Mineral Processing Model Definition
- Stage 5 - Multivariate Spatial Model Generation
- Stage 6 - Joint Mining and Mineral Processing Optimization

However, depending of the evolution status in the mining development process some or all stages are considered in the economic assessment such as:

- Exploration
Stages 1 and 5
- Conceptual or scoping
Stages 1 - 3
- Pre-feasibility
Stages 1 - 4
- Feasibility
Stages 1 - 6
- Operation
Stages 1 - 6

An experienced multidisciplinary teamwork approach is applied for the development and implementation of the six stage. The multidisciplinary team consists of geologists, geophysicists, geochemists, geotechnicians, petrologists, mineralogists, geostatisticians, mining engineers, metallurgists and economists. The level of involvement of the team is also controlled by the evolution status in the development process in mining projects and operations.

A concise explanation of the functionality of each stage is described in the subsequent sections. Nevertheless, the major strength of the geometallurgy framework is its open technological platform, which adopts state of the art methodologies that take into account multiple sources of uncertainty.

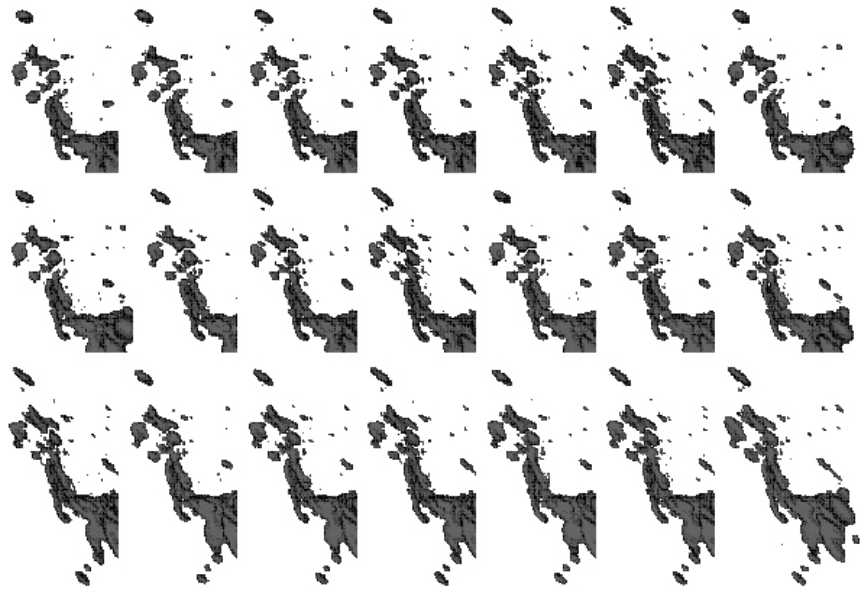

Figure 2: Multiple mutually exclusive spatial uncertainty domain models defined by applying and combining multivariate statistical analysis and implicit modeling of a lead-silver deposit

STAGE 1 - MULTIVARIATE SPATIAL DOMAIN DEFINITION

The main intention of this first stage of the risk adverse integrated methodology consists in defining mutually exclusive multivariate spatial uncertainty domain models in mineral deposits (Figure 2). The spatial domain models correspond to similar mineralogy and texture characteristics and perhaps with diverse mineral processing liberation and selectivity responses. These models are defined by applying and combining multivariate statistical analysis and implicit modeling methodologies. The analysis and modeling are carried out by constraining and determining mineral processing liberation and selectivity properties, which are explicitly contained in the extensive and integrated exploration drillhole database.

In this stage, a logical and reasonable knowledge about the spatial variability of the mineralogy and texture characteristics is essential, which describe the multiple events forming mineral deposits. These characteristics are related to the modal mineralogy, association, liberation, grain size, macrotexture, mesotexture and microtexture. Additionally, these characteristics allow understanding and identifying the main drivers that impact in the mineral processing liberation and selectivity process.

There are a number of direct and indirect methodologies that are currently applied in the mining industry in order to identify and quantifying the mineralogy and texture characteristics. Additionally, there are also complementary technologies and methodologies that measure the physical and chemical properties of the mineralization, which can be applied in determining the mineral processing response.

Mineral processing liberation and selectivity spatial uncertainty domain models are mutually exclusive and can be different in number and proportions in comparable mineral deposit types. The combined univariate, bivariate and multivariate statistical analysis and implicit modeling are applied in defining the number and proportion of spatial uncertainty domains. Moreover, a robust statistical analysis is also considered in describing the intrinsic variability of the mineralogy and texture in each domain. These spatial uncertainty domain models are fundamental in the subsequent mineral processing sample selection and multivariate spatial model generation stages.

Geometallurgy spatial uncertainty domain models are defined once the extensive and integrated exploration drillhole database is updated with mineral processing liberation and selectivity parameters. The drillhole database is then updated by applying

the defined mathematical models of each defined spatial domain, which correlate the mineralogy and texture characteristics with mineral processing liberation and selectivity parameters (Stage 4). The mineral processing parameters are determined from metallurgical and environmental testworks of selected variability samples (Stage 3). The variability samples are selected in each defined spatial uncertainty domain models (Stage 2). The confidence of the geometallurgy spatial domain models is improved through the iterative optimization process of the risk adverse methodology. The geometallurgy and other specific spatial domain models defined in this stage are essential sources of information in the multivariate spatial model generation stage (Stage 5). The function of these spatial domain models consist in constraining the stochastic geostatistical process. The spatial domain constrained geostatistical process allows increased confidence of the spatial characteristics and properties of mineral resources.

STAGE 2 - MINERAL PROCESSING SAMPLE SELECTION

The central purpose of this stage consists in selecting the optimum number of unbiased and representative samples within each defined mutually exclusive spatial domain model (Stage 1). The samples are selected from exploration drillhole core intervals by applying and combining multivariate statistical analysis, operation research techniques and Monte Carlo simulation method (Figure 3). The sample selection process assures that the samples are representative of the intrinsic spatial variability of the mineral processing liberation and selectivity properties (Figure 4). The process is constrained by the objective of the mineral processing and environmental assessment, which is directly related to the evolution status of the development process of mining projects and operations. In addition, the sample selection process takes into account the mass requirement of each testwork designed to evaluate mineral processing and environmental parameters.

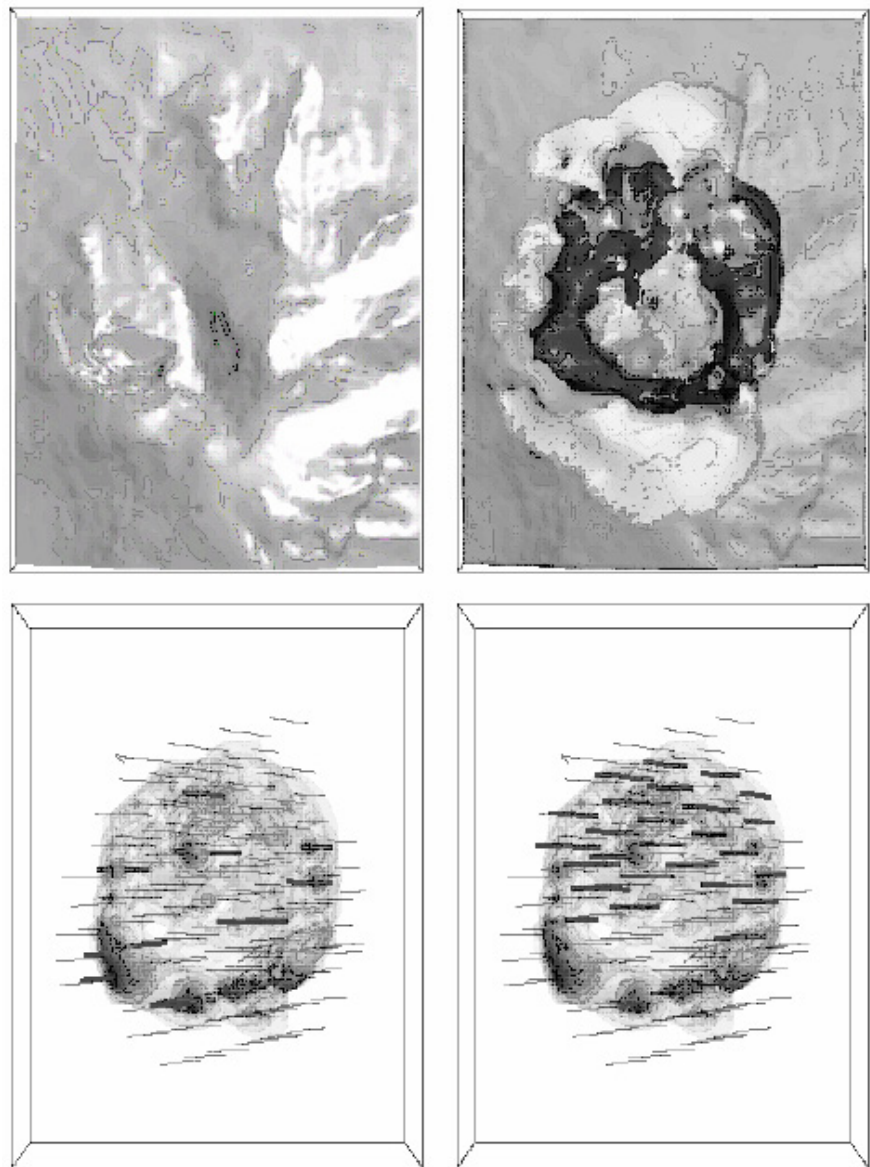

Figure 3: Mineral processing variability (bottom left) and bulk (bottom right) samples selected from mutually exclusive spatial domain (top right) model of a molybdenum deposit

The mineral processing samples are selected mostly from exploration drillhole core intervals, although occasionally, due to exceptional circumstances, they can be also selected from the reject or pulp materials. The latter is additionally depending on the designed method of mineral processing and environmental assessment. These selected samples of mineral deposits are essential for the development of the next stages of the geometallurgy framework.

Through this stage composite, master composite, variability, bulk and run of mine bulk sample types are selected. These samples are deemed representative of the entire range of the spatial variability of the mineral processing liberation and selectivity properties in mineral deposits.

Composite samples are selected by combining proportionally spatial discrete exploration drillhole core intervals. A master composite sample is subsequently a proportional combination of the individual composite samples. The objective of composite and master composite samples consists in assessing respectively the individual and overall mineral processing and environmental response of each defined spatial domain.

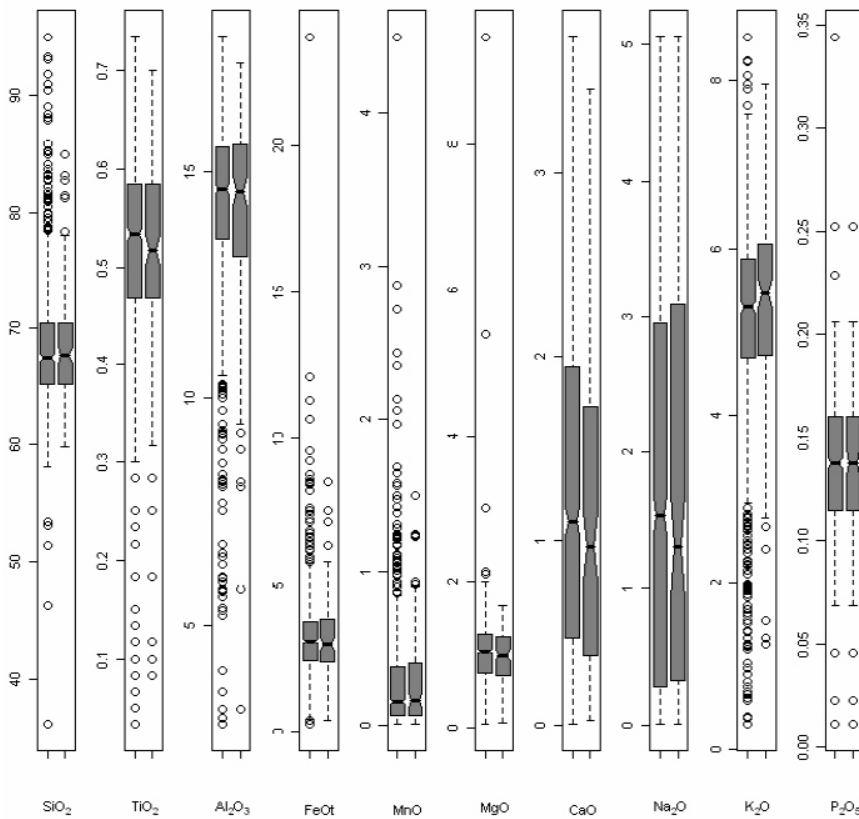

Figure 4: Box-and-Whisker diagram comparing the major elements between the population (left boxes) and selected variability (right boxes) samples by applying and combining multivariate statistical analysis, operation research techniques and Monte Carlo simulation method

Variability samples are chosen from spatial discrete exploration drillhole core intervals in each domain. The purpose of the variability samples consists in determining the mineral processing and environmental response specifically in the selected spatial locations in mineral deposits. Furthermore, those samples are fundamental for populating each spatial domain with mineral processing and environmental properties performed through the development of subsequent stages. The information derived from variability samples is essential in the development and implementation of the whole geometallurgy framework in mining projects and operations. An important point to highlight is that a selected variability sample is not used for various testworks. This means, that each sample is specially selected for specific testwork and taking into account the spatial and statistical variability of the mineral processing parameter to be assessed.

A bulk sample is gathered by combining proportionally spatial discrete exploration core and reject intervals. In this case,

the bulk sample is representative of the entire range of spatial variability of the mineral processing and environmental properties of ore resources. The bulk sample is analogous to the master composite sample but the main difference consists in that the mass of the bulk sample that is greater than master composite. The difference in mass is due to the specific requirements of the mineral processing pilot plant testwork. A run of mine bulk sample is similar in mass to the bulk sample and it is gathered from combining proportionally spatial discrete exploration drillhole core and reject intervals. The run of mine bulk sample is representative of specific production schedule over the life of the mining projects and operations.

STAGE 3 - MINERAL PROCESSING PARAMETER DETERMINATION

The aim of this stage consists in determining liberation and selectivity parameters based on mineral processing and environmental testworks from selected samples in each spatial domain

(Figure 5). However, the description of the mineral processing and environmental parameters determined by their respective tests is beyond the objective of this document. There are numerous and available publications that describe in detail the mineral processing and environmental testwork methods and parameters.

Mineral processing liberation and selectivity parameters determined from selected composites, master composite, bulk and run of mine bulk samples are valuable information. The information obtained from composites and master composite samples is essential for defining the conceptual mineral processing flowsheet design. The information generated from bulk and run of mine bulk samples is indispensable in confirming the defined mineral processing flowsheet design over the expected life of mining projects and operations. Moreover, this information is useful in determining the overall expected quantity and quality of concentrates or products. However, it cannot be used in defining the optimum

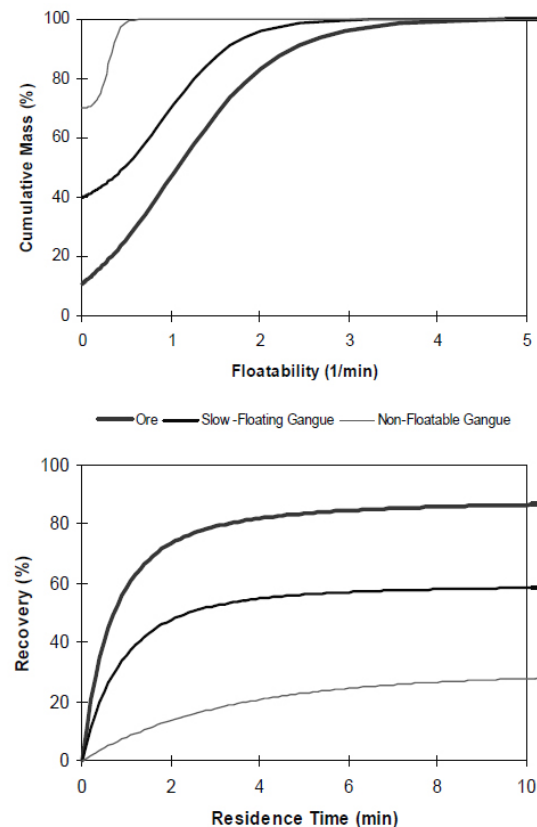

Figure 5: Mineral processing selectivity parameters from selected variability samples of specific defined spatial domain

economic solution of mining projects and operations. This solution is reached by taking into account the spatial uncertainty of the variability of mineral processing liberation and selectivity parameters determined from the selected variability samples. Mineral processing parameters determined from selected variability samples are elemental information for the previous (Stage 1) and subsequent (Stage 4 - 6) stages. Other important component of this stage consists in identifying those mineral processing liberation and selectivity linear, non-linear, additive and non-additive parameters. These parameters are significant source of information in the integrated optimization process and specifically in maximizing the quantity and quality of liberated and selected ore minerals.

STAGE 4 - MULTIVARIATE MINERAL PROCESSING MODEL DEFINITION

The principal function of this stage consists in defining multivariate mathematical models for each spatial domain. The mathematical models correlate mineral processing and environmental parameters determined in the previous stage with mineralogy and texture characteristics of selected variability samples (Figure 6). The multivariate mineral processing models are defined by applying mathematical methodologies.

The mineral processing and environmental response of each spatial domain is represented by individual or general mathematical models. An unlimited number of multivariate linear and non-linear mathematical models can be defined and related to mineral processing and environmental parameters. These defined linear and non-linear mathematical models are important for the previous (Stage 1) and next (Stage 5) stages. Through these mathematical models the extensive and integrated exploration drillhole database is updated with mineral processing and environmental parameters. Then, updated geometallurgy spatial uncertainty domain models are defined taking into account these parameters. These mathematical models are also

indispensable for populating the mineral resources models with these parameters by using geometallurgy spatial domains.

Multivariate additive and non-additive mathematical models can be also defined in this stage and identified as transfer functions. The transfer functions take into account mining, blending, stockpiling and processing ore reserves with different mineralogy and texture characteristics (Figure 7). These functions are mainly relating to each component of the mineral processing flowsheet design. The main application of the transfer functions is in the joint mining and mineral processing optimization stage of the geometallurgy framework. Through the defined transfer functions in each component of the mineral processing flowsheet design the expected concentrates and products of liberated and selected ore minerals are then optimized.

STAGE 5 - MULTIVARIATE SPATIAL MODEL GENERATION

The most important objective of this stage consists in generating mutually exclusive multivariate spatial uncertainty models of mineral deposits (Figure 8). The spatial uncertainty models can be merged all together and then a geometallurgy stochastic mineral resources model is generated. The uncertainty models contain multivariate attributes mainly relating to the spatial variability of the mineralogy and texture characteristics and mineral processing liberation and selectivity properties. The models are generated by applying geometallurgical domain constrained multivariate geostatistical methodology and multivariate mathematical models defined in the previous stage. The geostatistical process is performed by accessing characteristics and parameters explicitly contained in the extensive and integrated exploration drillhole database.

The geometallurgy stochastic mineral resources model contains discrete and continuous variables associated with the spatial uncertainty of the variability of multivariate attributes in mineral deposits. The main attributes are related to geological, geochemical, geotechnical, mineralogical, textural, metallurgical

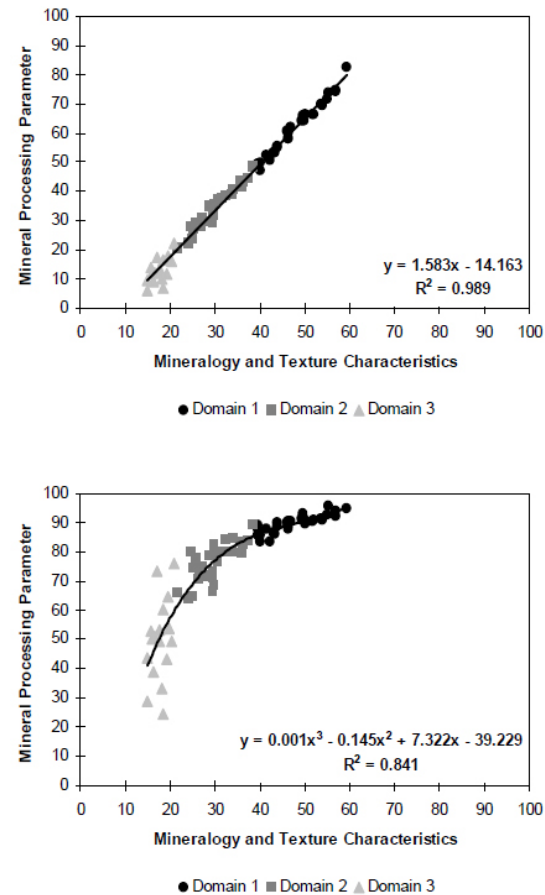

Figure 6: Multivariate mineral processing mathematical models that correlate mineral processing parameters with mineralogy and texture characteristics from selected variability samples

and environmental information. The geometallurgy stochastic mineral resources model can be updated at any time depending on the availability of new source information. These mineral resources model is indispensable for the development of the next stage relating to the joint mining and mineral processing optimization stage (Stage 6).

Specific spatial domain models previously defined in the multivariate spatial domain definition stage (Stage 1) are also applied in constraining the geostatistical process performed in this stage. The main objective of the specific spatial domains consists in increasing the confidence of the spatial characteristics and properties in the stochastic mineral resources. This means, that specific spatial domain can be applied in constraining the simulation process of particular attribute.

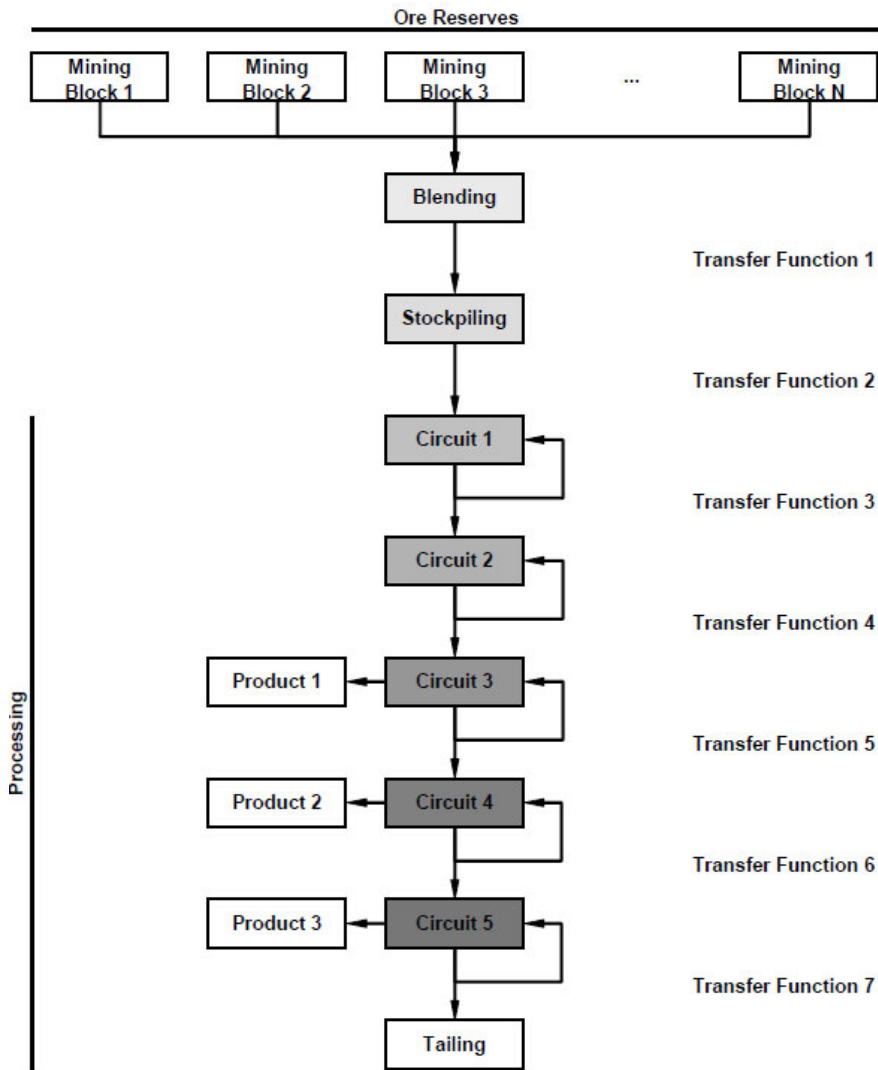

Figure 7: Transfer functions of a generalized mineral processing flowsheet design

STAGE 6 - JOINT MINING AND MINERAL PROCESSING OPTIMIZATION

The development and implementation of the risk adverse integrated geometallurgy framework in mining projects and operations ends with this last stage. However, the geometallurgy framework is an iterative and integrated optimization process that is carried out a number of times due to the recent sources of information that is available. Additionally, when further corporate strategies or scenarios are considered then a new economic assessment is needed.

The previous five stages of the risk adverse integrated methodology consisted in defining, selecting, determining and generating the information required for the corporate strategic planning process of mining projects and operations. Precisely, the information is then condensed in the extensive and integrated geometallurgy stochastic mineral resources model generated in the previous stage (Stage 5). The mineral resources model contains discrete and continuous variables regarding to the spatial uncertainty of the variability of multivariate attributes. Although, the most important multivariate attributes are related to the mineralogy and texture characteristics and mineral processing liberation and selectivity parameters in mineral deposits.

The objective function of this stage consists in maximizing the economic value of mining projects and operations, which is subject to geological, mining, metallurgical, environmental, marketing, economics and corporate constraints or scenarios. A stochastic mathematical formulation is specially developed by applying operation research techniques in finding the optimum economic solution. The optimum solution is obtained through a trade-off among mining, blending, stockpiling and processing ore reserves with distinct mineralogy and texture characteristics. The geometallurgy uncertainty mineral resources model and the defined transfer functions are the important information

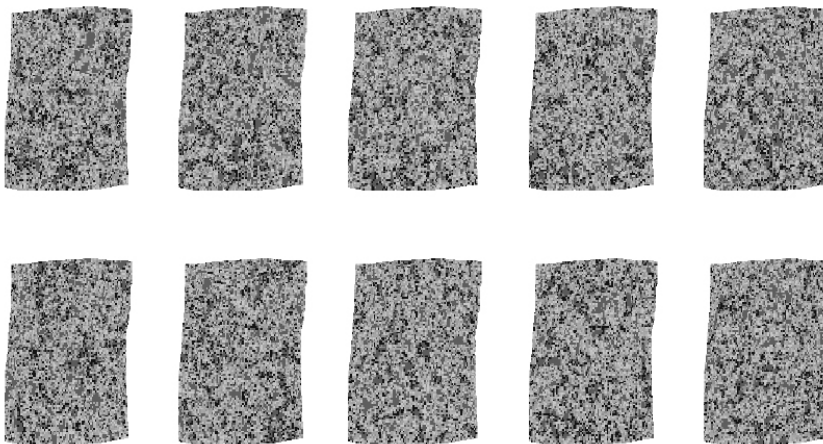

Figure 8: Mineral processing selectivity parameter spatial uncertainty models generated by applying sequential Gaussian simulation algorithm of a gold and copper deposit

required by the mathematical formulation. The optimization process takes into account the additive and non-additive transfer functions to deal with the mining, blending, stockpiling and processing ore reserves with different mineral processing liberation and selectivity properties (Figure 9). Through this mathematical formulation, a concurrent and integrated optimization process that maximizes the concentrates or products of liberated and selected ore minerals from mineral deposits is performed. The concurrent optimization determines both the practical mining sequence of ore reserves and the dynamic and robust mineral processing flowsheet design over the expected life of mining projects and operations.

An adapted multiple cut-off grades optimization theory is included in the mathematical formulation that takes into accounts the mineralogy and texture characteristics instead of grades. Mineral processing liberation and selectivity parameters are also incorporated in the formulation. The optimum and adapted multiple cut-off grades over the life of the mine dynamically impact in the modifying factors in converting concurrently mineral resources in ore reserves.

In summary, the optimum economic solution of mining projects and operation is reached through an iterative and concurrently risk adverse integrated optimization process. The optimum solution is based on a realistic trade-off among mining, blending, stockpiling, processing, smelting, refining and marketing the spatial uncertainty of the variability of ore reserves with different characteristics and parameters. The optimization process is concurrent due to that simultaneously the mine design, ore reserves, mining sequence, production scheduling and mineral processing flowsheet design are determined.

CONCLUSIONS

The most important conclusions of the vision for a risk adverse integrated geometallurgy framework are:

- The geometallurgy framework is an integrated methodology that complements the risk analysis in the economic evaluation of mining projects and operations and is an essential component in the corporate strategic planning process
- In addition, the geometallurgy framework is an open technological platform structured in an ordered and coherent sequence of iterative stages, which adopts state of the art methodologies that take into account multiple sources of uncertainty
- The risk adverse methodology maximizes concentrates or products of liberated and selected ore minerals based on spatial uncertainty of the variability of mineralogy and texture characteristics and mineral processing liberation and selectivity properties in mineral deposits
- The integrated methodology concurrently determines the optimum and practical mining sequence of ore reserves and dynamic and robust mineral processing flowsheet design over the life of mining projects and operations.

ACKNOWLEDGEMENTS

The author acknowledges the support of SGS Corporate Management with special thanks to Mike Belton, Executive Vice President of SGS Mineral Services, for the approval in publishing this paper. Thanks are extended to SGS geologists, mineralogists and metallurgists colleagues for their time, effort and contribution in reviewing and commenting the vision for a risk adverse integrated geometallurgy framework.

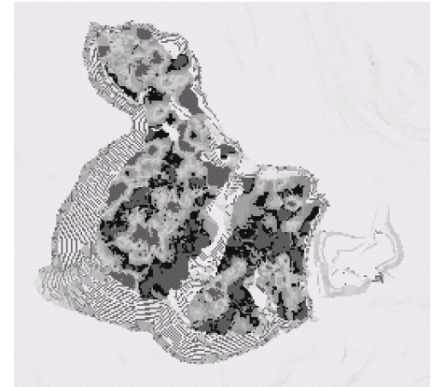

Figure 9: Mineral processing selectivity parameter open pit ore reserves of an iron oxide-copper-gold deposit

CONTACT INFORMATION

SGS Mineral Services
1140 Sheppard Avenue West, Unit 6
Toronto, Ontario, Canada
M3K 2A2
PH: +1 (416) 633 - 9400

Email us at minerals@sgs.com

WWW.SGS.COM/MINERALS

© 2011 SGS. All rights reserved. The information contained herein is provided "as is" and SGS does not warrant that it will be error-free or will meet any particular criteria of performance or quality. Do not quote or refer any information herein without SGS' prior written consent. Any unauthorized alteration, forgery or falsification of the content or appearance of this document is unlawful and offenders may be prosecuted to the fullest extent of the law.